

WG1 – EV's and lifting

Equip-Auto 2011

Thursday 13th October

EGEA WG1

Electric vehicles

**What are the potential issues surrounding
'lifts and lifting'
of electric vehicles?**

Neil Pattemore – Technical Advisor - EGEA

WG1 – EV's and lifting

Focus on actual lift issues:

- **Vehicle dimensions?**
 - Size**
 - Weight**
- **Weight distribution?**
- **Special vehicle handling?**
- **Vehicle components:**
 - Motors**
 - Batteries**



EV - Lithium Batteries

Chevy Volt



Hyundai LPG Hybrid

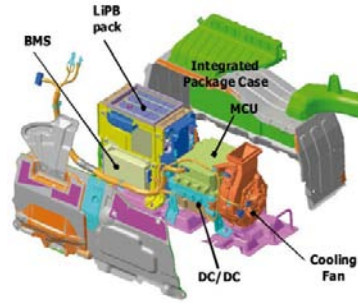

Toyota Prius PHEV



Daimler S400 Hybrid

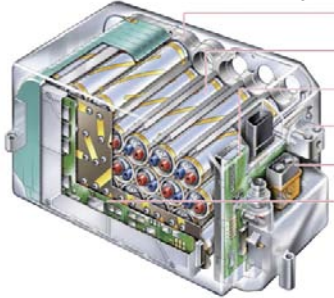

Variety of
battery layouts
& placements

Mitsubishi i-MIEV



Nissan Leaf



Ford Focus EV

Battery handling

Pallet for EV battery

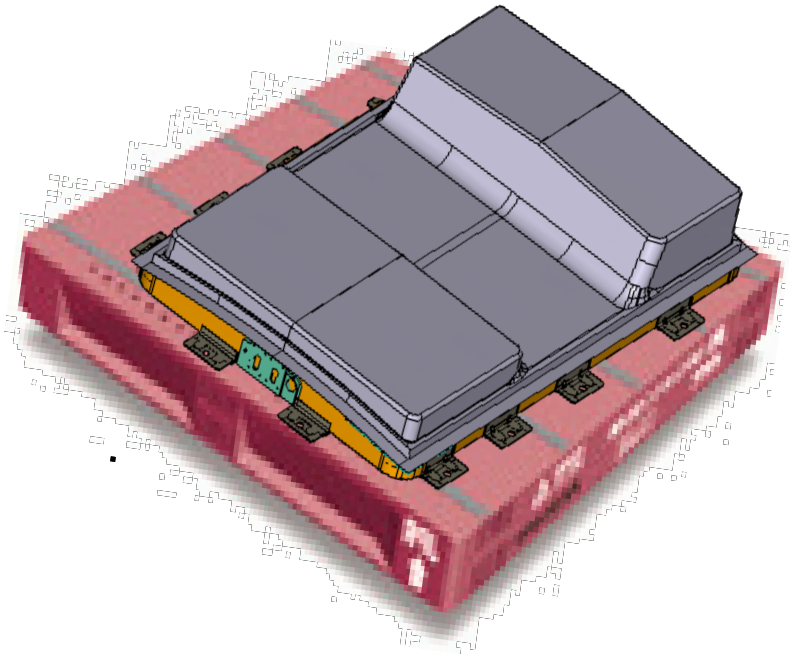

- To locate the LiB battery on the pallet to ease transportation.
- Designed to ensure that the centre of gravity of the battery is in the right place
- to lock the battery on the palette
- to match with the protective cover for transportation

Battery handling

EV Battery lifting table

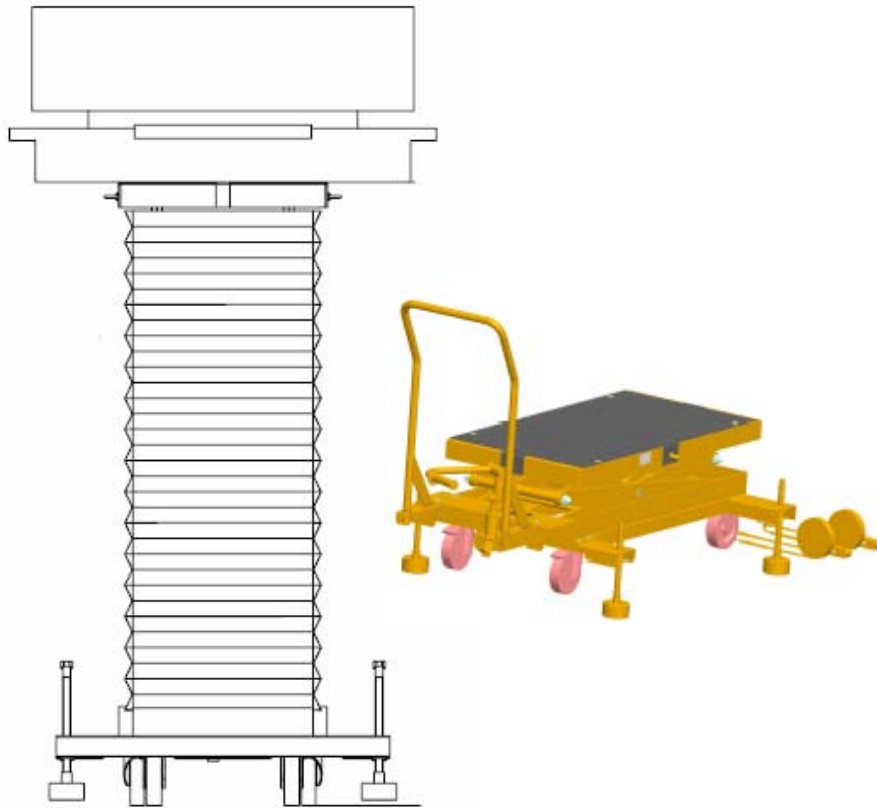

- To install or remove the LiB Battery
- Overall size: 1694x 100 x 482 mm
- Table size: 1200 x 600
- Maximum height: 1770 mm
- Lifting capability : 1000 Kg in static, or 500 Kg in dynamic (e.g lift moving).
- In order to align the battery into the floor plan of the vehicle, the 4 feet are adjustable (table is parallel to the car)
- Belt mechanism provides a push (battery) / pull (vehicle) to avoid pushing the vehicle when the battery is installed.
- Safety valve anti-drop, 4 stabilizing feet and accordion side-protection.
- Includes a Rubber mat and 2 belts

Battery handling

Battery stacker



- To safely handle/position the LiB onto the transportation pallet.
- Capacity = 650kgs
- Maximum Fork Length = 1200mm
- Vertical Travel = 1500mm
- Min Fork Height = 90mm
- Max Fork Height = 1590mm
- Strokes to max height = 102
- Overall Dims.: H 1967 x W 883 x L 1851mm

Battery handling

Foldable Mobile Floor Crane



- To handle the battery and move it onto the work bench for repair.
- Folds quickly and requires only a small space for storage
- Telescopic boom provides extra reach (166cm and height 244cm). Dim: 500 x 400 x 1600 mm
- Swivel hydraulic unit. The pump piston spring improves operation allowing the user to be close to the load for final approach.
- Release handle with “Dead man’s” operation provides maximum lowering precision
- Polyamide wheels and castors facilitates maneuverability with no damage to the floor
- Position: 1:500Kg, 2: 400Kg, 3:325Kg

Battery handling

Battery load leveler

Without Load leveler

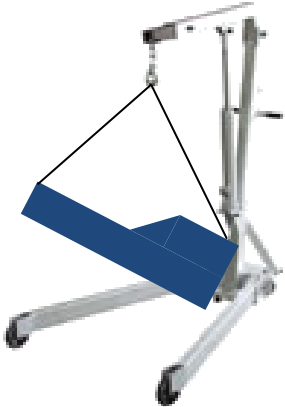

With Load leveler

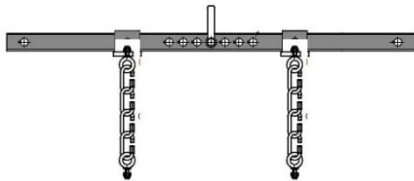
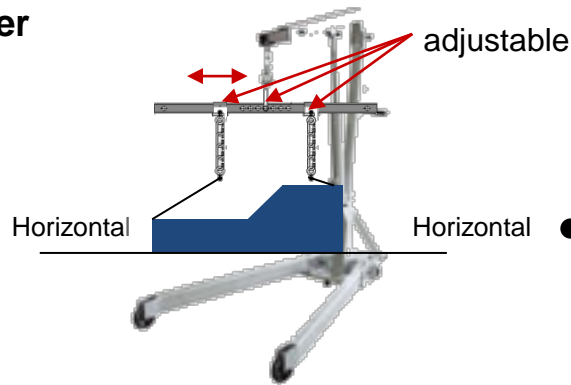

- This tool ensures the correct balancing of the weight of the battery to allow the battery crane to be safely moved
- Weight capacity ranging between 270 and 400 kgs
- 4 chains of 4 carabineers

Battery handling

KIT: BELT SLING & CARABINEERS

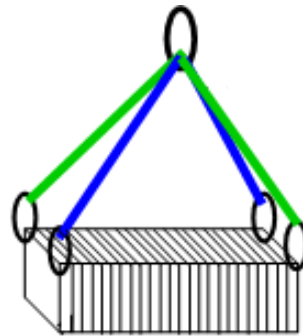

- To allow the battery to be properly hung from the crane hook and then moved
- From pallet to lifting table
- From lifting table to inspection table
- Includes 2 Belts, 1 large carabineer and 4 small carabineers.
- Made of non-electrically conductive material.
- Belt Dimensions: H 2000 x W 25 x T 2 mm
- Capacity: 400kg/belt